

# CLECO AIR DRILLS

## FEATURES:

- Compact ergonomic design provides small, powerful, easy-to-handle tool.
- Down handle muffled exhaust for quiet operation.
- 3-idler gear planetary gear trains for longer service life.
- Durable sand-cast handle.
- High parts interchangeability with #5 Series screwdrivers and nutrunners.
- Ergonomic handle grip sleeve.
- Ergonomic trigger for precise speed control.

## NO. 5 SERIES DRILL

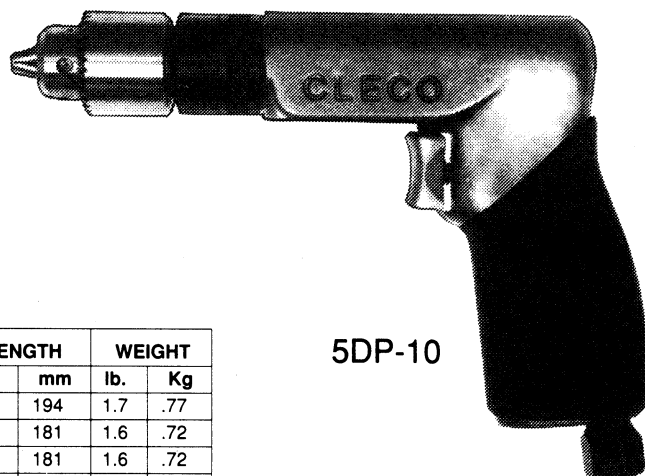

5DP-10

## SPECIFICATIONS

MODEL NUMBER	FREE SPEED	STALL TORQUE		CHUCK CAPACITY		LENGTH		WEIGHT	
		in. lb.	Nm	in.	mm	in.	mm	lb.	Kg
5DP-7	650	70	7.9	¼	7 7/8	194	1.7	.77	
5DP-10	1100	43	4.8	¼	7 7/8	181	1.6	.72	
5DP-25	2800	21	2.4	¼	7 7/8	181	1.6	.72	
5DP-40	4500	11	1.2	¼	7 7/8	181	1.6	.72	

PERFORMANCE RATED AT 90 PSIG  
(6.2 BAR) AIR PRESSURE  
AIR INLET: ¼ N.P.T.  
MINIMUM HOSE SIZE: 3/16 IN. (4.7 MM)  
SPINDLE OFFSET: .57 IN. (14.5 MM)

### STANDARD EQUIPMENT:

Operating Instructions and Service Manual  
Handle Grip(203762-0)  
3-jaw Chuck (849102-9) and Key (849116-9)

### OPTIONAL EXTRA CHARGE EQUIPMENT:

¼ x 8 ft. Hose Whip (881283-6)  
¼ x 8 ft. Polyurethane Hose Whip (201696-2)

Speed Range: 650 to 3800 rpm

Nominal Motor Power .3 HP

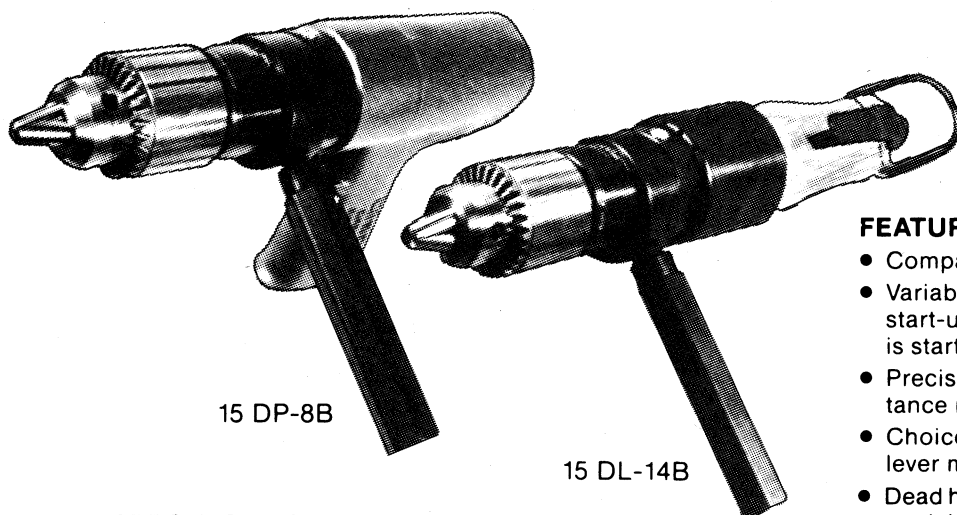

15 DP-8B

15 DL-14B

## NO. 15 SERIES DRILLS

Speed Range: 160 to 3000 rpm

Nominal Motor Power 1.0 HP

## FEATURES:

- Compact, powerful tools develop one horsepower
- Variable speed trigger on pistol models allows slow start-up to begin hole, high speed drilling after hole is started
- Precision ball-bearings located at maximum distance minimizes bit run-out
- Choice of well-balanced pistol model or comfortable lever model
- Dead handle is standard equipment on higher torque models

## SPECIFICATIONS

MODEL NUMBER	FREE SPEED rpm	STALL TORQUE		CHUCK CAPACITY (SEE CAPACITY NOTE)		LENGTH		WEIGHT		
		ft. lb.	Nm	in.	mm	in.	mm	lb.	kg.	
<b>PISTOL GRIP MODELS</b>										
15 DP-1.6B	160	160†	217†	½	13	9 ¼	248	6 *	2.7	
15 DP-4B	400	44†	60†	½	13	8 ½	216	5 ½*	2.5	
15 DP-8B	800	22	30	½	13	8 ½	216	5 ½*	2.5	
15 DP-14B	1400	14	19	¾	10	8 ¼	210	4 ¼	2.0	
15 DP-20B	2000	10	13.5	¾	10	7 ¼	184	4 ¼	1.9	
15 DP-30B	3000	7	9.5	¾	10	7 ¼	184	4 ¼	1.9	
<b>STRAIGHT HANDLE MODELS</b>										
15 DL-4B	400†	44	60	¾	10	10	254	5 ¼*	2.4	
15 DL-8B	800	22	30	¾	10	10	254	5 ¼*	2.4	
15 DL-14B	1400	14	19	¾	10	10	254	5 ¼*	2.4	

AIR INLET: ¾ N.P.T.F.  
MINIMUM HOSE SIZE: ¾ IN.  
SPINDLE THREAD: ½-20  
SPINDLE OFFSET:  
PISTOL GRIP: 3/16 IN.  
LEVER: 1 1/2 IN.

### STANDARD EQUIPMENT:

3-JAW CHUCK AND KEY.  
OPERATING INSTRUCTIONS AND SERVICE MANUAL.  
DEAD HANDLES ON ALL MODELS EXCEPT 15 DP-14B,  
15 DP-20B AND 15 DP-30B.

\*INCLUDES DEAD HANDLE.

† THEORETICAL STALL TORQUE BASED ON GEAR REDUCTION. THESE TOOLS ARE INTENDED FOR SLOW SPEED APPLICATIONS AND NOT HIGH TORQUE APPLICATIONS. HIGH MAINTENANCE SHOULD BE EXPECTED IF TOOLS ARE OPERATED ABOVE 25 FT. LBS.

**CAPACITY CAUTION NOTE:** PISTOL GRIP 15 SERIES DRILLS SHOULD BE EQUIPPED WITH DEAD HANDLE (881580) WHEN USED WITH CHUCKS LARGER THAN ¾ IN. CAPACITY. STRAIGHT HANDLE 15 SERIES DRILLS SHOULD NOT BE EQUIPPED WITH CHUCKS LARGER THAN ¾ IN. CAPACITY.